

XURON
CORP.



precisiontools

DESIGNED FOR CUTTING EXCELLENCE

hand tool ergonomics Q&A.

Q. What are ergonomic hand tools?

A. All hand tools, by definition, are ergonomic, otherwise you wouldn't be able to do any work with them. What's really important are the ergonomic enhancements that have been (or can be) made to your tools. Let's examine several different aspects:

1. Force — The amount of force required to use a tool includes the force necessary to overcome resistance in joints and any return spring(s) in addition to the force actually required to cut, grasp or bend. XURON manufactures only Micro-Shear® wire cutters. Their patented shearing cut requires about half the force required by a conventional compression-style cutter to cut wire. High precision screw and post joints on the 9000 Series reduce internal friction and our return springs provide lively action with low operating pressure.

2. Comfort — A number of factors determine if a hand tool is comfortable: the shape of the grip and its size, the amount of contact surface with the hand and the contour of the contact surface, the resiliency of the grip material, and the overall weight of the tool; all influence whether the tool will be comfortable in your hand. The comfort of the tool should be apparent the moment it's picked up. Comfort should also be assessed after extended use.

Micro-Shear® Flush Cutter grips feature broad, flat contact surfaces molded from Xuro-Rubber™. The grips on the 9000LH tools traverse the width of the hand, helping to eliminate pressure points while reducing pressure at any given point. Grip spread in the closed position is under 2", a comfortable dimension for most hand sizes. Weight is very low, ranging from 1.9 oz. for a 170-II to 2.7 oz. for a 9000LH Series shear.

3. Visual — Reflective surfaces cause glare, which promotes eye strain and fatigue. Positioning, especially in dense areas or under adverse lighting conditions, is troublesome and fatiguing if there is poor contrast between the tool and the workpiece.

XURON tools feature a non-glare bright finish or a



glare-eliminating black finish, giving you the option of selecting the appropriate finish for the work.

4. Auditory — High sound levels in the workplace are another important fatigue factor. XURON 590 Micro-Pneumatics™ help reduce workplace noise levels with their quiet operation (<60 DbA).

Q. Will hand tools with ergonomic enhancements eliminate cumulative trauma disorders (CTD), such as carpal tunnel syndrome?

A. No. No hand tool, regardless of ergonomic enhancement is capable of being a "magic bullet" and eliminating possible cumulative trauma disorders. The enemy is still the repetitive nature of the work and fatigue. With ergonomically-enhanced hand tools fatigue is postponed and trauma is reduced. The goal is to postpone fatigue to the point where a rest period occurs before the tool user fatigues.

For the estimated 20% of the population that is predisposed to CTD, no hand-operated tool is going to eliminate the problem. Assessing the work and the people doing the work is essential in choosing appropriate tools. Some form of automation, such as a pneumatic tool, is indicated in high volume, repetitive motion work situations.

WIRE STRIPPERS PLIERS AND FORMING TOOLS

Wire Strippers, Pliers and Forming Tools



450 Tweezer Nose™ Plier

The 450 is an ultra-precise needlenose plier capable of grasping and holding wire less than 1 mil thick with the strength for wire forming. Leads "popping" free, tip mis-alignment and blade crossover will be a memory once you switch to our Tweezer Nose™ pliers. Radiused edges protect lead wires. Light weight and our patented, non-protruding, *Light Touch™* return spring help ensure operator comfort.

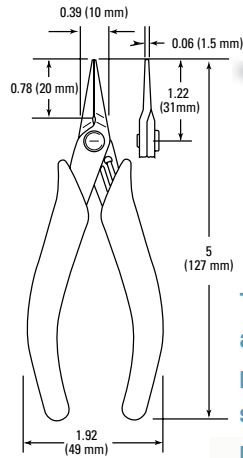

The model 450 is also available with fine, perpendicular-to-the-jaw serrations for extra holding power (model 450S).

new 450BN Bent Nose Plier

Strong and precise plier blades angled to 45° for improved sight lines when working in tight areas or with small parts. Plier tips are perfectly aligned and capable of picking up a human hair or forming and holding wire. Glare-eliminating black finish, non-slip Xuro-Rubber™ grips and *Light Touch™* return spring combine to ensure operator comfort even during periods of extended use.

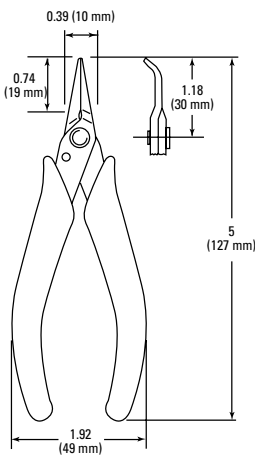

485 Xuro-Grip™ Long Nose Plier

A true "electronics production long nose plier" is what we had in mind when we designed the 485. Engineers and production managers told us traditional drop-forged designs were too bulky and lacked the sensitive "feel" required for precision electronic assembly. Our 485 performs where the competition failed. 485 features a thin profile for access in high density areas, radiused outside edges, ergonomically-shaped, non-slip Xuro-Rubber™ grips, a glare-eliminating black finish and light weight for operator comfort. The model 485 is also available with fine, perpendicular-to-the-jaw serrations for extra holding power (Model 485S).

new 485C Combination Shear/Long Nose Plier

The combined benefits of a full by-pass shear cutter and a precision electronics long nose plier in one tool. Heat-treated, durable, high carbon steel blades allow a cutting range from the smallest wire up to 12 AWG (2.05mm) copper wire. Plier blades are tapered for access into restricted work areas and have radiused outside edges for forming wire without damage or scarring. Non-protruding *Light Touch™* return spring speeds work while cushioned, non-slip Xuro-Rubber™ grips provide comfort.

new 485FN Flat Nose Plier

A flat nose (duck bill) version of our Model 485 Long Nose Plier. Flat, smooth blades are perfect for wire bending or forming operations. As with all Xuron pliers, the 485FN features a glare eliminating black finish, ergonomically shaped Xuro-Rubber™ grips, and light weight for operator comfort.

475 Xuro-Grip™ Short Nose Plier

High carbon steel for strength and an extra-slim profile to allow access in high density areas. The strength to crimp a lead wire with the precision to grasp and hold a human hair. Plier features a glare-eliminating black finish, ergonomically-shaped, non-slip Xuro-Rubber™ grips and light weight for operator comfort.

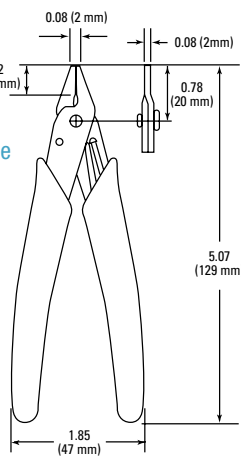

The model 475 is also available with fine, perpendicular-to-the-jaw serrations for extra holding power (Model 475S).



475C Combination Shear/Short Nose Plier

A true multi-purpose tool, combines a full by-pass shear with a precise short nose plier. Extra strong, high carbon steel plier has the power to grip and the precision to hold a human hair. Shear cuts everything from small wires up to 12 AWG (2.05mm) copper wire.

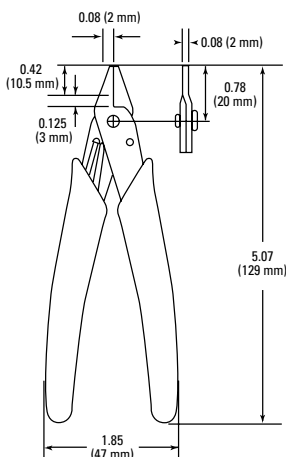

WIRE STRIPPERS, PLIERS AND FORMING TOOLS

AND WIRE STRIPPERS, PLIERS AND FORMING TOOLS

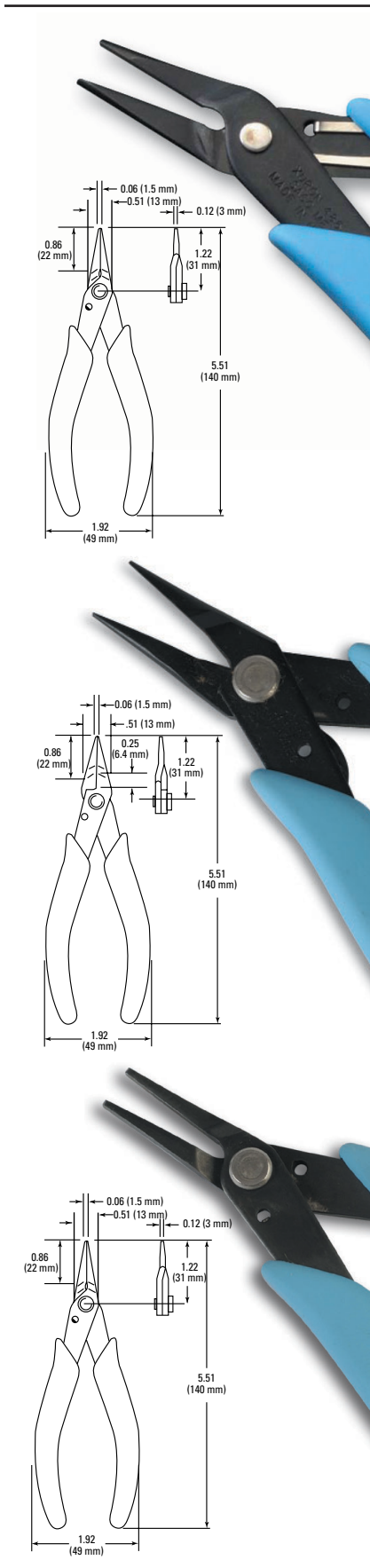

488 Round Nose Plier

Traditional double-round design with an innovative difference. Conventional round tip transitions to an elliptical shape along the length of the blades. This design allows for more forming possibilities and exceptional tip strength. Ideal for forming or looping of very fine wires in precision work. Xuro-Rubber™ grips and light weight ensure operator comfort.

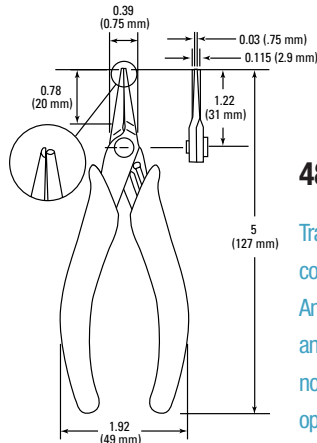
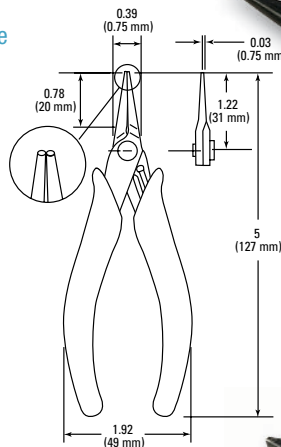

489 Combination Tip Plier

Traditional one round/one flat design offers easy coiling, forming and bending - all with one plier. An extremely durable tool with exceptional tip strength and precision closure. Glare-eliminating black finish, non-slip Xuro-Rubber™ grips and light weight ensure operator comfort.

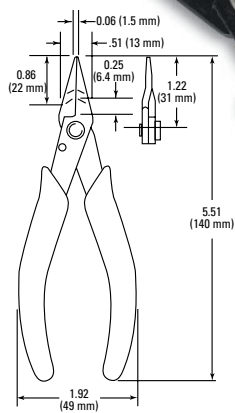

573 Xuro-Former™ Lead Forming Tool

The patented, original strain-relief forming hand tool. Radius and depth of bend are controlled by a simple slide adjuster, which locks firmly in place to prevent unintended setting changes. This high carbon steel tool features light weight, glare-eliminating black finish and ergonomically-shaped, non-slip Xuro-Rubber™ grips. Forms lead wires up to 0.030" (0.8mm).

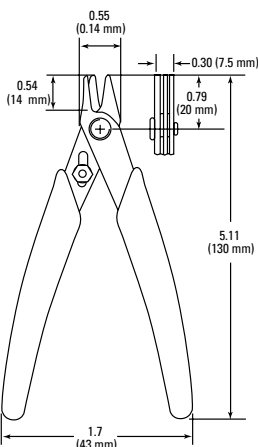
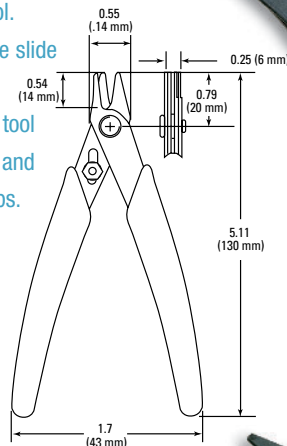

573L Xuro-Former™ Lead Forming Tool

The same great features as our 573 Xuro-Former™ but designed to form wires up to 0.050" (1.3mm).

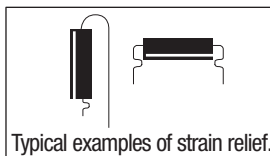

pliers

Precision Work Demands Precision Pliers.

Pliers are used as an extension of the hand, especially for jewelry making. They need to be precise, light weight, durable and have a good 'feel.' Xuron® brand Pliers deliver on all counts.

Tweezer Nose™ Pliers

#450

We call this a 'tweezer nose' pliers because the blades are fine, precise, and match perfectly in alignment, size and shape. Capable of picking up and holding delicate parts, while strong enough to form and bend wire. Available with either smooth jaws (450) or serrated (450S) for improved grip.

Bent Nose Pliers

#450BN

A bent nose version of the Model 450 TweezerNose™ Pliers. The 45° bend allows your wrist to remain in a more comfortable neutral position. The angle of the pliers blades is perfect for wire wrapping and making wrapped loops.

Chain Nose Pliers

#485

Strong but not bulky, this pliers has long jaws that are smooth inside with rounded outer edges so you can use them for holding, bending, forming and manipulating wire, as well as strips or sheets of soft metal.

Flat Nose Pliers

#485FN

Flat, straight blades are ideal for bending, forming and flattening both wire and soft metals. As opposed to a chain nose pliers, the flat nose has wider blades that provide a stronger grip.

Combination Shear/Chain Nose Pliers

#485C

The combined benefits of a full bypass shear cutter and precision chain nose pliers in one tool. Cuts soft wire up to 12 ga. (2.05 mm). Pliers' blades are tapered for access into restricted work areas and have rounded outside edges for forming wire without damage or scarring.

Short Nose Pliers

#475

A 'go-to' pliers for chainmaille work. The pliers blades are just the right size for holding, opening and closing jump rings.

Short Flat Nose Pliers

#483

A short, flat nose pliers designed for chainmaille jewelry artists. Smooth, 3 mm wide jaws provide extra gripping surface on jump rings for increased control and stability. Can be used with stainless steel, bronze, bright aluminum, niobium, silver and copper jump rings up to 14 ga. (1.6 mm). Add our Model 487 Chisel Nose Pliers for the perfect chainmaille pliers set.

90° Bent Nose Pliers

#486

Designed by a chainmailler for chainmaille artists! The 90° bend of the pliers blades keeps your wrist in a natural position and makes it simple to pick up a jump ring and then quickly transition into opening/closing the ring.

Chisel Nose Pliers

#487

Flat, smooth blades with tips ground to a 45° angle. This provides extra gripping surface on a jump ring while eliminating interference with the open working space of the ring. Especially useful for micromaille and other very small work.

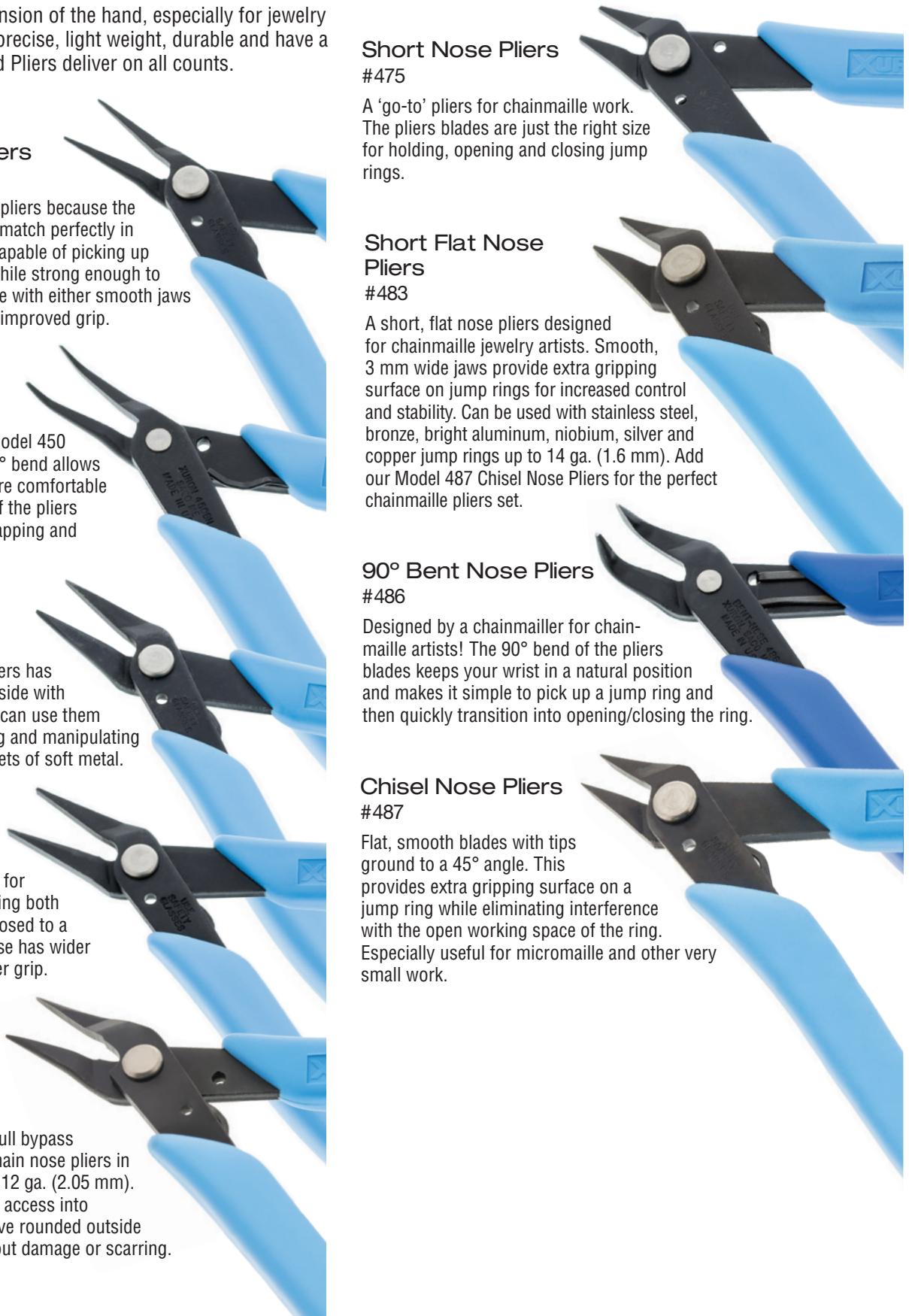

pliers

Round Nose Pliers #488

This unique round nose pliers has super fine round tips and the pliers blades transition to an elliptical shape for multiple looping and forming possibilities. Best used with small soft wire.



Split Ring Pliers #496

Opening split rings is fast and easy with this pliers. Simply insert the 'tooth' of the pliers between the rings and squeeze the handles – no more broken finger nails!



Four-in-One Crimping Pliers #494

Precisely and securely crimps and folds 1, 2 and 3 mm crimp tubes and includes a 'bonus' chain nose pliers at the tip. The pliers can be used to provide an extra squeeze to the crimp tube, open a loop or pick up small beads/findings. The bright lime green handle is easy to spot and will stand out from your other tools.

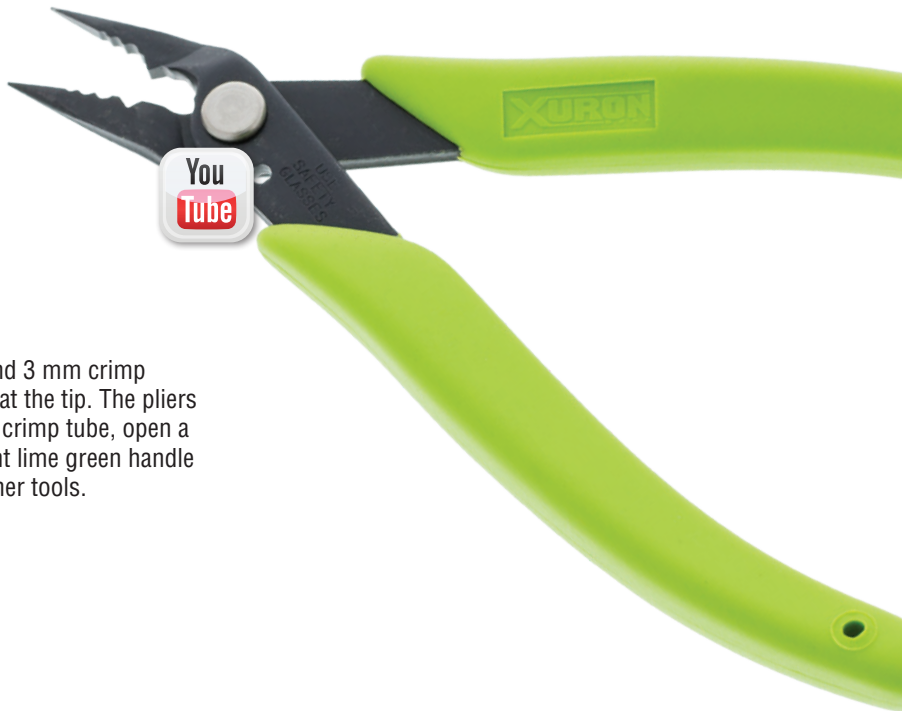

How to use the 4 in 1 Crimper

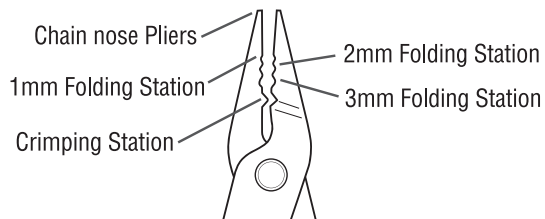

Step #1: Place crimp in the Crimping Station. Squeeze firmly.

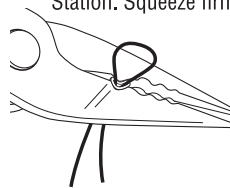

Step #2: Turn crimp on its side. "<" Place in the appropriate size Folding Station. Squeeze firmly.

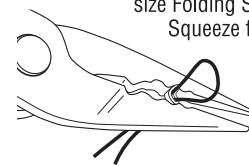

Step #3: Use the chain nose tip of the pliers for any additional squeezing or bending.